

# MLS20-2R

## User Manual



Dinacell Electronica S.L.

The contained information in this document is subject to changes without previous notice. The content shown here should be used as general product information. It should not be interpreted as a guarantee of quality or durability. Electronic Dinacell shall not be liable for technical or editing errors or omissions contained in this document.

Product Notice:

This manual describes the features that serve the product in its most up-to-date version. The resources included in this manual serve the MLS20-2R model. Not all resources are available in all MLS20-2R editions or versions.

**Document Ref.: D1943-04**

**Publication date: 30/06/2023**

**Firmware version: 2.04**

For more information

---

**[www.dinacell.com](http://www.dinacell.com)**

# INDEX

---

<b>1 Introduction</b> .....	4
1.1 General Overview .....	4
1.2 Main Characteristics .....	4
1.3 CAN connection scheme .....	4
<b>2 Know your Device</b> .....	5
2.1 Dimensions, label, display and keyboard .....	5
2.2 Inner part, connection .....	6
2.4 Electrical specifications .....	6
<b>3 Structure and usage of the device</b> .....	7
3.1 Structure of the menus and parameters of the device .....	7
3.2 Keyboard Features .....	8
<b>4 Settings Menu</b> .....	9
4.1 Settings Menu .....	9
4.2 Display submenu .....	10
4.3 Calibration submenu .....	10
4.4 Relay submenu .....	11
4.5 Alarm submenu .....	12
4.6 Analog output submenu .....	13
4.7 CAN Communication Submenu .....	13
4.8 ADC submenu .....	14
4.9 Information Submenu .....	14
<b>5 Latest Loads Menu</b> .....	15
5.1 Last Load Menu .....	15
<b>6 Tare function</b> .....	16
6.1 What is Tare function? .....	16
6.2 What is Tare for? .....	16
<b>7 Device Update</b> .....	16
7.1 Firmware update .....	16
<b>8 Errors and overflows</b> .....	17
8.1 Error codes .....	17
8.2 Display overflow .....	17
<b>9 Step by step installation guide</b> .....	18
9.1 Setting up the device.....	18
9.2 Display setup .....	18
9.3 Device calibration .....	18
9.4 Relay setup .....	18
9.5 Communication settings .....	19
<b>10 Calibration data back up</b> .....	19
10.1 Visualization copy .....	19
10.2 Calibration copy .....	19

## Introduction

### 1.1 General Overview

The MLS20-2R is a load measurement and monitoring device developed by Dinacell Electronics. Specially designed for installations on the frame at the foot of the silo. It displays the weight of the tank contents, both numerically on the display and on the percentage level LED bar. It features two relays, that can be configured to different functions. Equipped with analog output 4-20mA or 0-10V and with CAN communications bus.

### 1.2 Main Characteristics

- Measures and controls loads in silos.
- Supports up to 8 individual sensors or load cells.
- 5-digit display, 5 LED indicators and LED bar as a visual indicator of the load level.
- Two relays with programmable function.
- Analog output 0-10V.
- Analog output 4-20mA.
- CAN communication.

### 1.3 CAN connection scheme

For installations with more than one MLS20-2R device connected to the CAN network, look at the connection diagram.

 The (Device 1) and (Device n) are located as line endings. These devices should be configured as end-of-line. For more information, see section 4.7.

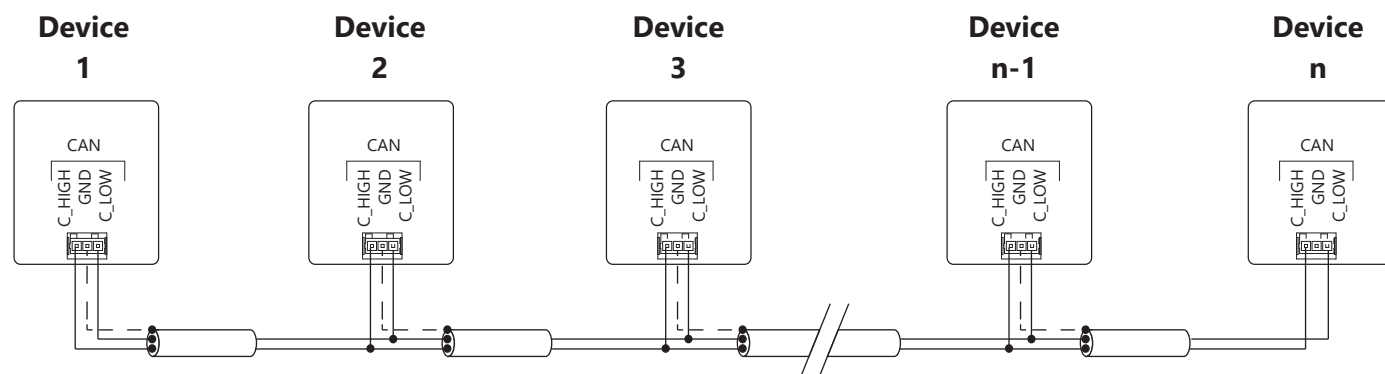

--- = Discontinued lines represent the mesh

**n** = Total devices connected to the CAN network.

## 2.1 Dimensions, label, display and keyboard

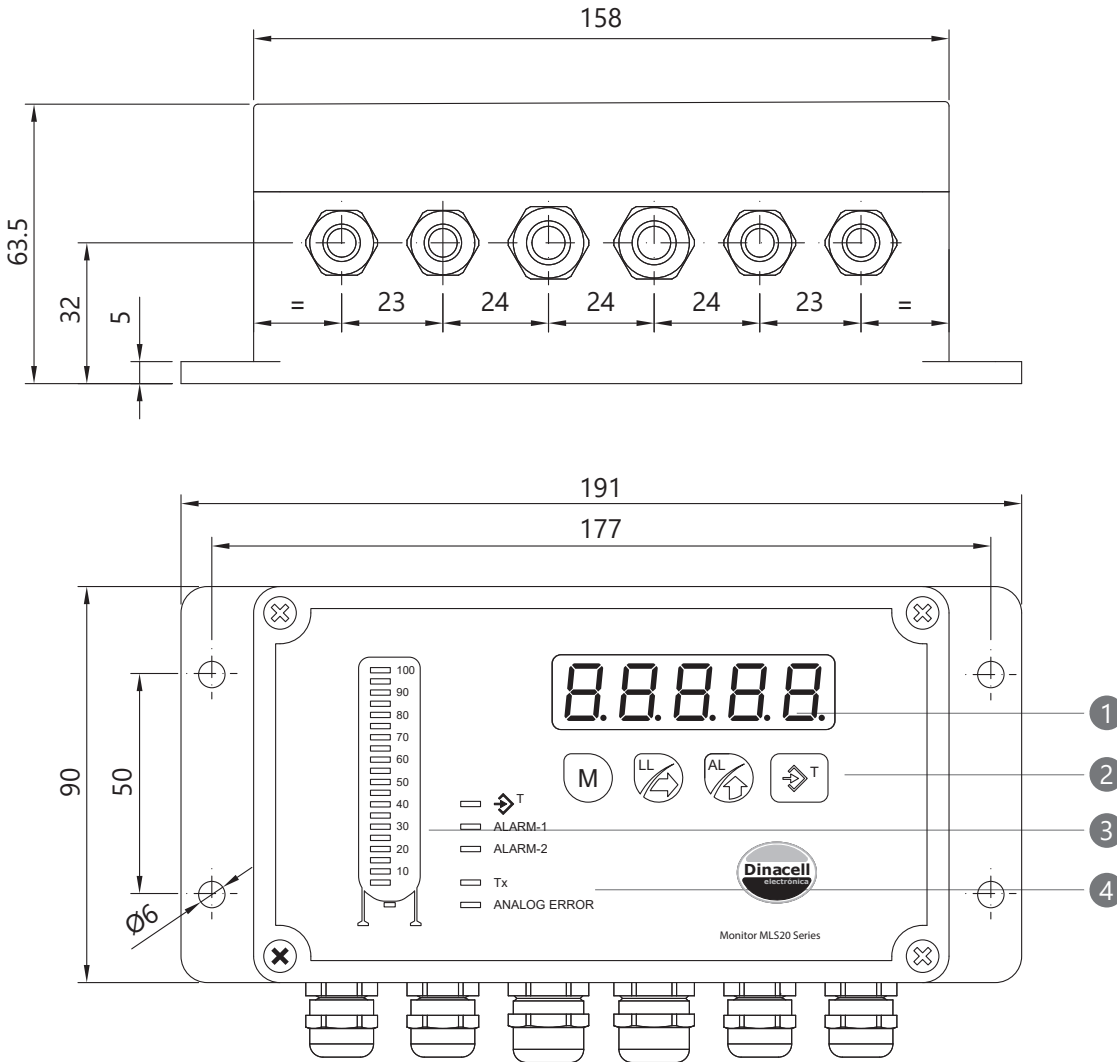

Component	Description	
(1) Display.	5-digit display.	
(2) Button keyboard.	The usage of the buttons is indicated in Chapter 3.2	
(3) LED bar.	Percentage level of the maximum load.	
(4) Leds status indicators.	T	Active Tare indicator.
	ALARM-1	Active alarm 1 indicator.
	ALARM-2	Active alarm 2 indicator.
	Tx	Fixed when there is communication and flickering to indicate an error.
	ANALOG ERROR	The led light will flash to indicate that there is an error. And will remain off, to indicate that the analog output is working properly.

## 2.2 Inner part, connection

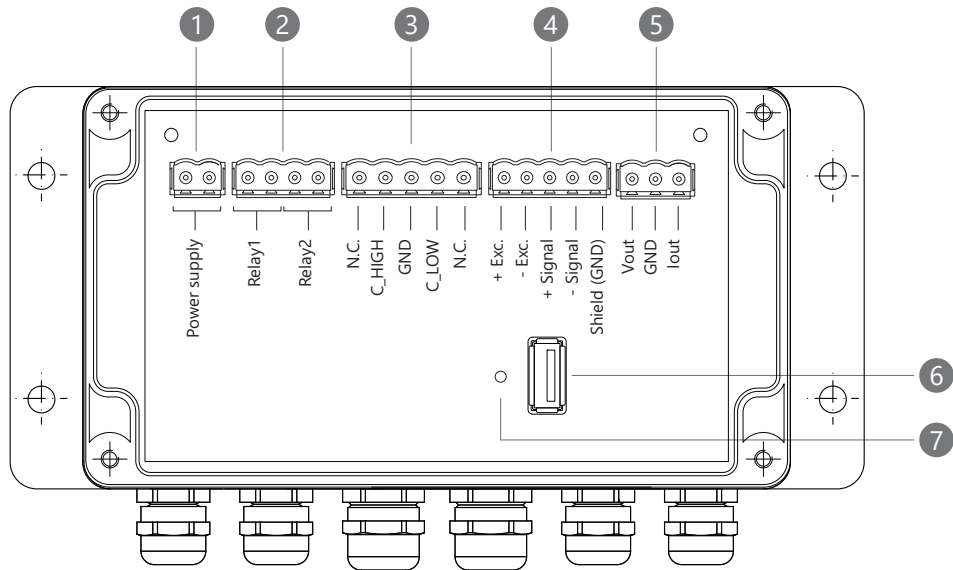

Component	Description								
(1) Power connection	Terminals for 80-260 Vac power supply.								
(2) Relays connection	Free potential contact for external device control.								
(3) CAN Communication.	CAN communications bus terminals.								
(4) Load cell connection	<table border="1"> <tr> <td>+ Exc.</td> <td>Red</td> </tr> <tr> <td>- Exc.</td> <td>Black</td> </tr> <tr> <td>+ Signal</td> <td>Green</td> </tr> <tr> <td>- Signal</td> <td>White</td> </tr> </table> Shield (GND)	+ Exc.	Red	- Exc.	Black	+ Signal	Green	- Signal	White
+ Exc.	Red								
- Exc.	Black								
+ Signal	Green								
- Signal	White								
(5) Analog outputs	Output proportional to the measured weight in the range of 0-10V or 4-20mA as set by the corresponding analog output menu parameter (Chapter 4.6). The common signal for both is GND.								
(6) USB for firmware update.									
(7) Firmware update Led indicator.									

## 2.4 Electrical specifications



Power supply characteristics.	Short-circuitable: no fuse needed to be replaced.
Voltage / Frequency.	80-260Vac / 50-60Hz
Maximum consumption.	3W
Relay contact.	(250Vac -3A) (30Vdc-3A)

## Structure and usage of the device

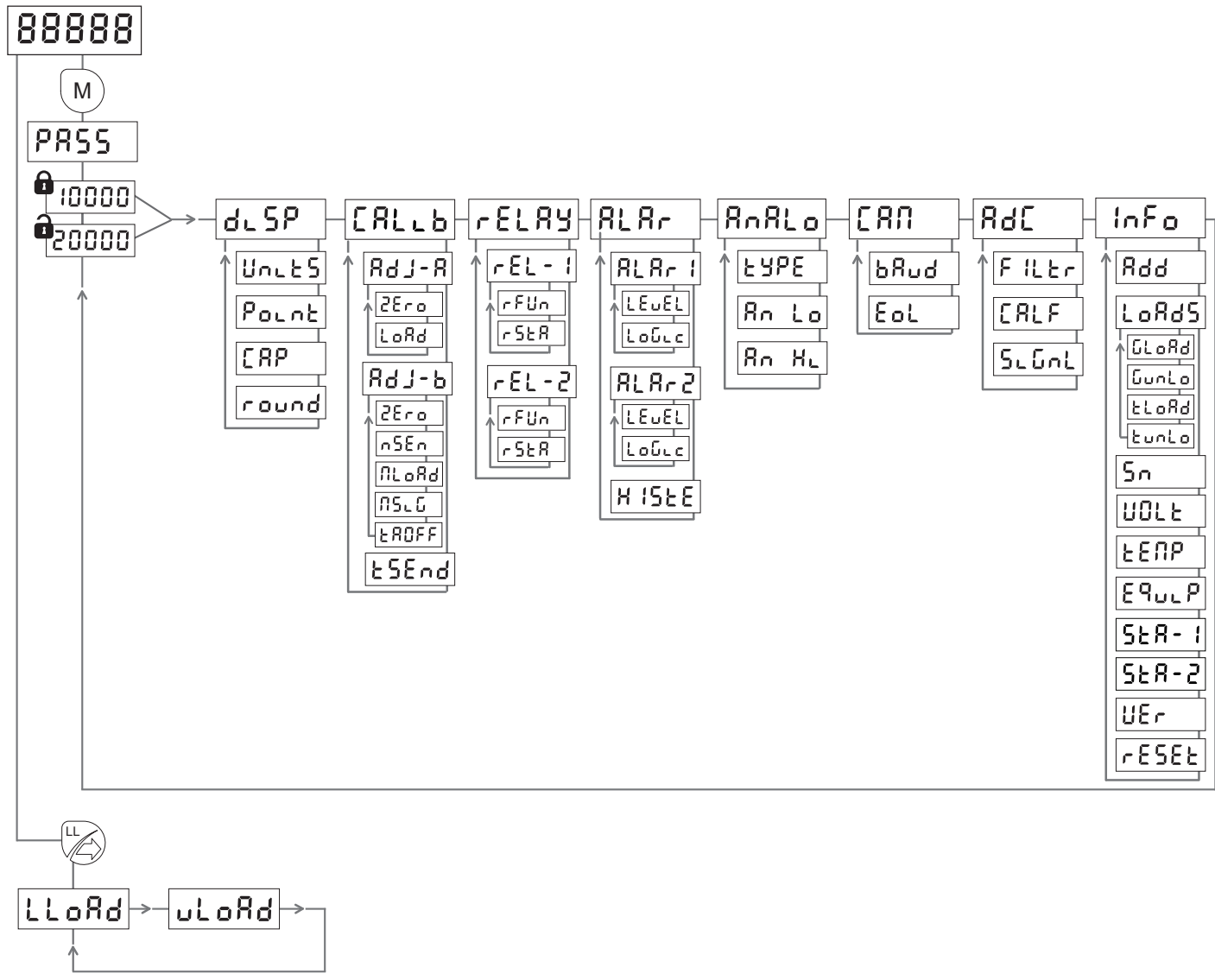
### 3.1 Structure of the menus and parameters of the device



## 3.2 Keyboard Features

Keys	State	Functions
	From the weight indicator.	Keep pressed to enter or exit from the settings menu.
	Inside the menus.	Press to navigate.
	Modifying a parameter.	Press once to confirm the value and when the display flashes press a second time to save the value.
	From the weight indicator.	Press and hold to enter or exit the last loads menu.
	Inside the menus.	Press to enter inside a submenu or parameter.
	Modifying a parameter.	Press to choose the digit to modify.
	From the weight indicator.	<p>With a relay associated with the alarm function, when the alarm is active, you can press to arm or disarm the associated relay by changing its state. The display will tell <code>R1_OF</code> or <code>R2_OF</code> when disarming the alarm relay 1 or 2, and <code>R1_ON</code> or <code>R2_ON</code> if armed. In case multiple relays are associated with the alarm function and both alarms are active, when you press the button, the display will show you the different alarm options. You must select and confirm the alarm that requires arming or disarming.</p> <p>With a relay associated with the manual function, press and hold to change the relay status. The display will tell <code>r1OPE</code> or <code>r2OPE</code> when relay 1 or relay 2 goes into an open state and <code>r1CLD</code> or <code>r2CLD</code> when they switch to closed. In case multiple relays are associated with the manual function you must select and confirm the relay that needs to change state.</p>
	Inside the menus.	Press to visualize the value of the parameter selected.
	Modifying a parameter.	Press to change the value of the digit or the options to be displayed.
	From the weight indicator.	<p>Press to make a temporary tare (it will not be saved).</p> <p>If one or more relays are associated with the Tare function, when the tare function is activated it will change the relay state associated with that function.</p>
	From the weight indicator.	Press and hold to exit the temporary tare.

## 4.1 Settings Menu

### 4.1 Settings Menu

The display of your device will show you, by default, the weight indicator. In order to enter or exit the settings menu you have to press and hold the (M) button from the weight indicator.

The menu has a cyclic structure as shown in the diagram below. Once inside, the first parameter that will appear will be `PR55` (password). It is necessary to enter the parameter and enter the display password or parameter modification password, in order to access the rest of the menu. Correctly entering the password will allow you to access it without having to re-enter it for 2 hours.

Settings Menu	Description
<code>PR55</code>	Access password. Operation required to access the menu. <div style="display: flex; justify-content: space-between;"> <div style="border: 1px solid black; padding: 2px;"><code>10000</code></div> <div>Enter the value "10000" to access the menu in display mode.</div> </div> <div style="display: flex; justify-content: space-between;"> <div style="border: 1px solid black; padding: 2px;"><code>20000</code></div> <div>Enter the value "20000" to access the menu in change mode.</div> </div>
<code>dLSP</code>	Display submenu of the device. In this submenu you can change the appearance and display mode of the values displayed on the display.
<code>CALCb</code>	Device calibration submenu. This submenu will allow you to calibrate your device in different ways and adjust the data sending time.
<code>rELAY</code>	Relay submenu. Programming the function and relay status.
<code>ALARr</code>	Alarms submenu. device alarm programming.
<code>AnALo</code>	Analog output Submenu.
<code>CAN</code>	CanOpen submenu.
<code>AdC</code>	Submenu for displaying the signal of the sensors in mV/V.
<code>InFo</code>	Device information submenu.

## 4.2 Display submenu

Options submenu	Description
<pre> graph TD     dLSP[dLSP] --&gt; Units[Units]     Units --&gt; Point[Point]     Point --&gt; CAP[CAP]     CAP --&gt; round[round]     round --&gt; dLSP                     </pre>	<p><b>Weight units.</b> The choices are tons (set by default), kilograms, or pounds.</p> <p><b>Decimal point (three decimal places will be displayed by default).</b> Decimals can be moved or deleted. We must take into account the capacity of our tank versus the five digits of the display and the units of weight to place the decimal point.</p> <p><b>ⓘ</b> We recommend that you use decimal places to display the value. If you have a digit overflow (Chapter 8.2), we could move the decimals.</p>
	<p><b>Tank capacity.</b> Parameter to set the capacity of the tank.</p>
	<p><b>Rounding of the measurement units.</b> The options are 1, 2, 5 (default), 10, 20, 25, 50, 100, 200, 250 and AUTO.</p>

## 4.3 Calibration submenu

This menu describes how to configure the device to adjust the weight measurement. Within the submenu we will have to choose one type of calibration or another.

Setting A **Adj-A** : requires you to enter a known load to the tank, this load allows us to establish a weighing reference.

Setting B **Adj-b** : it is necessary to know the technical data of the cell, this option is only valid with load cells and not with level sensors, for example the SD-1000.

Options submenu	Description
<pre> graph TD     CALCb[CALCb] --&gt; AdjA[Adj-A]     AdjA --&gt; ZeroA[Zero]     AdjA --&gt; Load[Load]     AdjB[Adj-b] --&gt; ZeroB[Zero]     AdjB --&gt; nSen[nSen]     AdjB --&gt; nLoad[nLoad]     AdjB --&gt; nSig[nSig]     AdjB --&gt; tROFF[tROFF]     tSEnd[tSEnd] --&gt; CALCb                     </pre>	<p><b>SETTING A. Calibration with a known weight.</b></p> <p><b>Procedure to specify the weight of the current silo load.</b> By default the value that will appear will be "00000", if there is no load inside the tank, confirm this value. If the tank is loaded you must enter the value of the load and confirm.</p> <p><b>Procedure to set a reference value with a known weight.</b> The value of the load used for the calibration of the silo shall be at least 60% of the total silo capacity.</p>
	<p><b>SETTING B. Calibration with technical data.</b></p> <p><b>This is the same zero operation as in setting A.</b></p> <p><b>Parameter to specify the number of sensors connected.</b></p> <p><b>specify the nominal load of the cell.</b></p> <p><b>specify the nominal signal of the cell.</b></p>
	<p><b>⚠</b> This parameter is self-calculated by filling in the previous four parameters. The value of this parameter is used to copy calibration from one device to another (Chapter 10).</p>
	<p><b>Sending interval.</b> Time in seconds to send weight signals over a CAN network.</p>

## 4.4 Relay submenu

### Options submenu

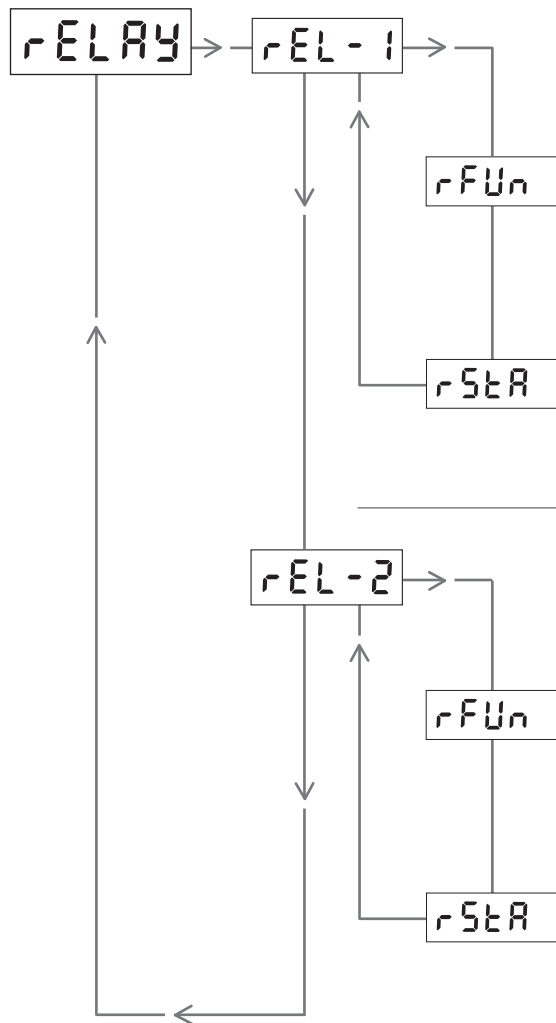

### Description

#### Relay configuration 1.

##### Relay function.

`_rALA` Associated with the alarm function, to be able to change the status of the relay when the "ALARM 1" is active.

`_rARr` Associated with the tare function, so that the relay status can be changed when the tare is activated.

`_rARA` Associated with the manual function, to be able to change the status of the relay directly.

##### Relay status.

The status of the relay at rest for a function that is not active.

`_OPEN` Usually open (set by default).

`_CLOSE` Usually closed.

#### Relay configuration 2.

##### Relay function.

`_rALA` Associated with the alarm function, to be able to change the status of the relay when "ALARM 2" is active.

`_rARr` Associated with the tare function, so that the relay status can be changed when the tare is activated.

`_rARA` Associated with the manual function, to be able to change the status of the relay directly.

##### Relay status.

The status of the relay at rest for a function that is not active.

`_OPEN` Usually open (set by default).

`_CLOSE` Usually closed.

## 4.5 Alarm submenu

In this submenu you can configure alarms, their address and hysteresis. If the relay is associated with the alarm function, when it is active, it is possible to change the status of the associated relay by pressing the . The alarm LED will flash to indicate that the alarm is active but with its relay unarmed. For more information, see button functions section 3.2.

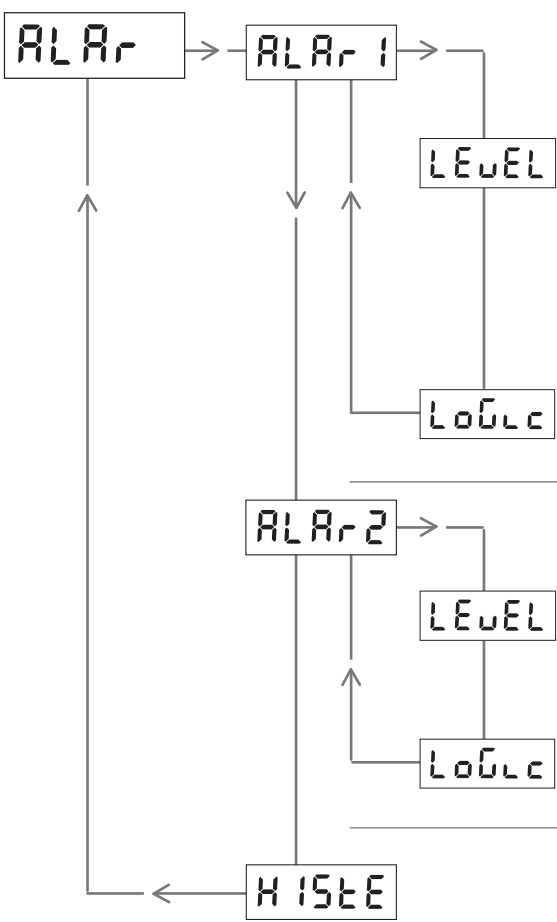
Options submenu	Description
	<p><b>Alarm 1 Setup.</b></p> <p><b>A value set for a load limit.</b> The default value is "00000", this setting disables the alarm. If a value is applied to the alarm, when that value is exceeded, the alarm will be triggered and if the relay is associated with the alarm function (Chapter 4.4) its status will change.</p>
	<p><b>Alarm logic.</b> Parameter to decide the direction of the alarm. If the alarm is triggered when the load exceeds the limit <input type="text" value="_HL"/>. If the alarm is triggered when <input type="text" value="_LO"/>.</p>
	<p><b>Alarm 2 Setup.</b></p> <p><b>A value set for a load limit.</b> The procedure of this parameter is the same as that of alarm 1 but applied to alarm 2.</p> <p><b>Alarm logic.</b> The procedure of this parameter is the same as that of alarm 1 but applied to alarm 2.</p>
<p><b>Alarm hysteresis.</b> Margin to switch from alarm status on to off. This parameter is used to prevent the alarm from constantly being activated and deactivated by small load fluctuations.</p>	

- Example A: If the configuration is:  = 1000 ,  =  y  = 100  
The relay will be activated when the silo weight exceeds the value of 1000.  
The relay will be disabled when the silo weight drops from the value of 900.
- Example B: If the configuration is:  = 1500 ,  =  y  = 200  
The relay will be activated when the silo weight drops from the value of 1500.  
The relay will be disabled when the silo weight exceeds the value of 1700.

## 4.6 Analog output submenu

The device is equipped with an analog output of 0-10V or 4-20mA configurable with the parameters of this submenu. This output is proportional to the weight measured between the values of the `Rn Lo` and `Rn Hl`.

Options submenu	Description
	<p><b>Analog output type.</b></p> <p><code>_4-20</code> 4-20mA Output.</p> <p><code>_0-10</code> 0-10V Output.</p>
	<p><b>Load value for minimum analog signal.</b></p> <p>Operation to indicate which load value we apply to 4mA or 0V.</p>
	<p><b>Load value for maximum analog signal.</b></p> <p>Procedure to indicate which load value we apply to 20mA or 10V.</p>

## 4.7 CAN Communication Submenu

This device is composed by a CAN communications protocol. In this submenu you will find the Baud Rate of the device.

Options submenu	Description
	<p><b>Baud Rate of the device.</b></p> <p>In this parameter we can select the transmission speed on our device. The transmission speed is proportional to the distance at which it is transmitted, the higher the speed the lower distance and vice versa. If the transmission rate selection is incorrect, no data will be available on the network. Transmission speeds are 50, 125 and 250kbps. The Baud Rate of the device is set by default to 50kbps.</p>
	<p><b>End of line.</b></p> <p>These devices feature an internal resistor that must be activated when the device is placed as the end of the line.</p> <p><code>_NO</code> For devices that are not positioned as end-of-line, this option is set by default.</p> <p><code>_YES</code> If the device is positioned as end of the line, select and confirm to activate the 120 ohm resistor.</p>

## 4.8 ADC submenu

### Options submenu

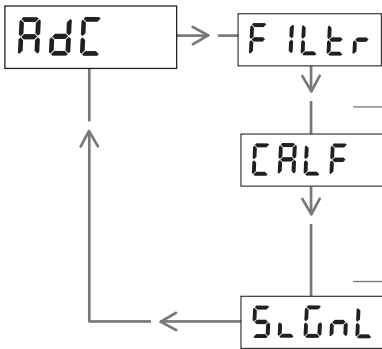

### Description

#### ADC filtering speed.

The higher the value the slower the conversion and the more stable the measurement.

#### ADC factory calibration.

This parameter is factory set, in case you lose this data you can recover it by entering the value printed on the label of your device.

Sensor signal in mV/V. (Read-only)

## 4.9 Information Submenu

### Options submenu

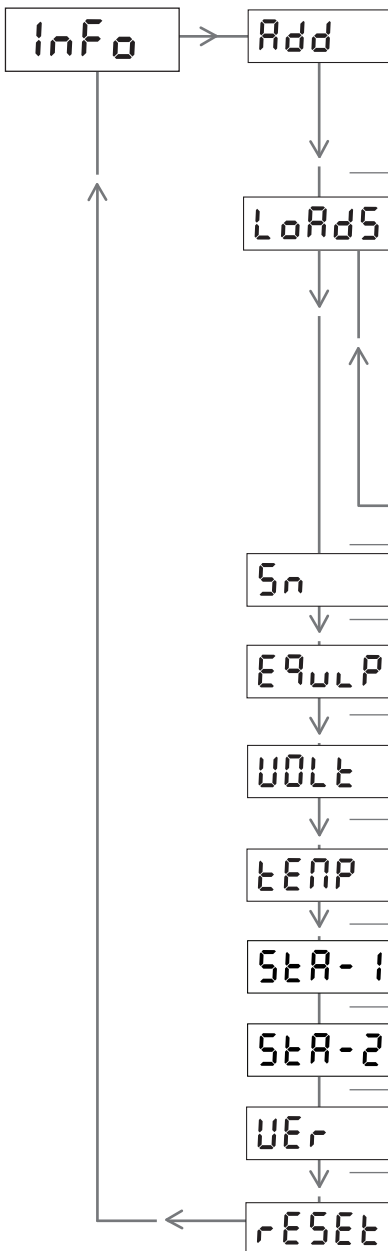

### Descripción

#### Device Address

In a multi-device network, you need to name each device with a different value. Make sure in a multi-device installation that the addresses are different. This address allows the device to differentiate itself from the rest.

#### Submenu to adjust the latest loads and discharges.

##### Weight margin to detect a load.

These values are auto adjusted with the calibration of the device.

##### Weight margin to detect a discharge.

These values are auto adjusted with the calibration of the device.

Standby time without detecting a weight variation until the loading is completed. Default 30".

Standby time without detecting a weight variation until a discharge is completed. Default 120".

Serial number (Read only).

Device Family Name (Read Only).

Internal device voltage (Read only).

Valid values around 12 VDC.

Internal temperature of the device. (Read only).

Repairs diagnostic parameter (Read only).

Updates diagnostic parameter (Read only).

Repairs diagnostic parameter (Read only).

Updates diagnostic parameter (Read only).

Firmware version. (Read only).

# Latest Loads Menu

## 5.1 Last Load Menu

The display of your device will show you the weight indicator by default. In order to enter or exit the last loads menu you have to press and hold the  button from the weight indicator.

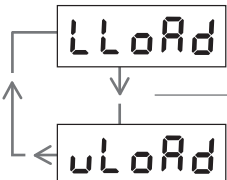

The menu has a cyclic structure as shown in the diagram below. Once inside, you will be able to see the last upload and the last download.

Latest Loads Menu	Description
	<p><b>Last load.</b> Display parameter of the last added load detected by the device.</p>
	<p><b>Last discharge.</b> Display parameter of the last discharge detected by the device.</p>

-  The Margin for the device to detect a load or discharge is covered in the settings menu within the info submenu. (Chapter 4.9)

# Tare function

## 6.1 What is Tare function?

This function is a second load indicator with a temporary zero. When making a Tare, measuring Load calculations will not be affected. Press key  to set a Tare in the display when the display is showing the Load measured. Tare LED switched ON indicates, that the Tare function is active, and at that stage, the display may show "00000". To exit tare function, keep pressing .

## 6.2 What is Tare for?

This function is meant to control directly the loading and unloading regardless of the actual load of the tank. In case of a loading being done when the tank is not completely discharged. The function tare avoids the need of taking values to calculate the weight of an added loading.

- Example: Let say we have a 6000kg capacity silo storing a load of 1000kg. We plan to load the silo with 3000kg, therefore we should activate the tare function to set the display to Zero "00000" and then, the MLS20-2R displayed load will increase as the Tank is being filled. Once the load is finished the display will show 3000kg. This is a temporary function so when deactivating the tare function, the load indicator will show 4000kg.

# Device Update

## 7.1 Firmware update

### Components and requirements for the upgrade:

- The device has a USB input for the update (paragraph 2.2).
- A FAT32 USB stick only containing the firmware update (file. CYP).







### The procedure for updating a device is as follows:

- 1) Copy the new firmware to a USB stick.
- 2) Turn off or disconnect the power from the device.
- 3) While holding  connect the power to the device. The USB LED will start flashing.
- 4) You must now connect the USB stick with the new firmware to the USB port of the device. The USB LED will flash faster.
- 5) Wait for the device to update the new firmware. The process can take up to a minute.
- 6) When the upgrade is complete, the device will reboot automatically.

# Errors and overflows

## 8.1 Error codes

When the device detects an error, one of the error codes in the following table will appear on the display.

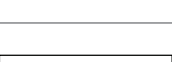
Error	Error description	Solution
	The Load cell or sensor is not properly connected, the wiring is damaged, or the sensor is broken.	Check the wiring.
	Sensor signal with Negative overflow. The load cell is giving a too high negative signal.	Check the wiring.
	Sensor signal with Positive overflow. The load cell is giving a too high Positive signal.	Exchange the load cell by another with Higher nominal load.
	Polarity error. Occurs when the device adjusts the weight with an inverted polarity or unloaded cell.	Check the wiring. Perform a new calibration.
	Loss of data in internal memory.  When this error appears the relays change to the state of OPEN.	Perform a Reset operation. Power cycle the unit and Restore the previous calibrating values stored (chapter 10).
	Load cell with very low sensibility. The unit was not properly adjusted, or load cell has a high nominal value.	Perform a new calibration.
	Load cell with very high sensibility. The unit was not properly adjusted, or load cell has a low nominal value.	Perform a new calibration.

 Important: When an error appears, all alarms are TURNED ON, and the relays transition into alarm state, except with error 6 that all relays are OPEN.

## 8.2 Display overflow

The MLS20-2R Display can indicate an overflow in two situations.

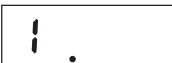
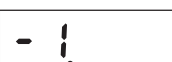
Overflow	Description	Solution
	Positive display overflow.	Reduce the number of decimal places.
	Negative display overflow.	Increase the number of decimal places.

# Step by step installation guide

**i** The usage of the buttons on the device is indicated in Chapter 3.2.

## 9.1 Setting up the device

9.1.1 Connect the load cells to the device. These devices have an individual cell input, in case you have multiple load cells you must use a sum box to join all the signals into a single output.

9.1.2 If using the device relays make the proper connections.

9.1.3 If multiple devices are communicated on a CAN network, make the proper connections.

9.1.4 To use analog output, make the proper connections.

9.1.5 Turn power on.

## 9.2 Display setup

**dLSP**

9.2.1 **Units** Select the weight units, by default tons.

9.2.2 **Point** Place the decimal point, by default three decimal places will appear on the device.

9.2.3 **CRP** Set the maximum silo capacity.

9.2.4 **round** Select the rounding type.

## 9.3 Device calibration

**CALCb**

The device can be calibrated in two different ways, (SETTING A) or (SETTING B). The (B SETTING) is only valid with load cells and NOT with level sensors such as SD1000 or SVS.

### 9.3.2 **Adj-A** (SETTING A)

- **ZERO** Perform the zero operation. It is recommended to do this operation with an empty silo, in case the silo has a load you must indicate within this operation the load and then confirm and save the value. If you do not know the weight of this load, you can enter an approximate value. When the silo is empty repeat the zero operation and enter a value of "00000".

- You will then need to fill the silo with a known weight load. The value of the load used for the calibration of the silo shall be at least 60% of the total silo capacity.

- **LOAD** You must indicate in this section the known weight value.

### 9.3.2 **Adj-b** (SETTING B)

- **ZERO** Perform the zero operation. It is recommended to do this operation with an empty silo, in case the silo has a load you must indicate within this operation the load and then confirm and save the value. If you do not know the weight of this load, you can enter an approximate value. When the silo is empty repeat the zero operation and enter a value of "00000".

- **SEn** indicate in this section the number of load cells connected to the device.

- **NLOAD** indicate in this section the nominal capacity of the load cell, refer to the label.

- **NSLG** indicate in this section the nominal signal of the load cell, refer to the label.

**i** Once the adjusting process has been finished, it is recommended to write down and store the required values in case that the calibration might be restored or the Unit replaced by a new one. (Chapter 10).

## 9.4 Relay setup

If you use the relays of the device, you must configure them with a function and a status.

9.4.1 **rFUN** Can be attributed to each relay with alarm function, manual function or tare function.

9.4.2 **rSTR** Taking into account the assigned function, you must set the idle state of the relay when the assigned function is not active.

## 9.5 Communication settings

9.5.1 **ALAR** If you need the alarms you must configure them. Everything you need to know about the types of alarms and how to set them up is indicated in section 4.5.

9.5.2 **ANALO** If you need the analog outputs you must configure them. Everything you need to know about analog output types and how to configure them is listed in section 4.6.

9.5.3 **CAN** If you communicate multiple devices over a CAN network, you must configure the devices that are located as end-of-line. You will find a CAN connection scheme in section 1.3 everything you need to know for the configuration of the devices as end of the line can be found in section 4.7.

## Calibration data back up

# 10

Once the MLS20-2R has been adjusted it is highly recommended to write down and save all the necessary data to restore the calibration of the device. In case that the data is lost, or the unit replaced, the previous calibration can be restored just by setting the previous values without performing a new calibration procedure.

### 10.1 Visualization copy

- UNITS** Weighing units.
- POINT** Decimal point Setting.
- CRP** Maximum Tank or silo Capacity.

### 10.2 Calibration copy

- nSEN** Number of sensors.
- ALOAD** Sensors nominal load.
- ASLG** Sensors nominal signal.
- TAOFF** Tare.

**Dinacell Electrónica S.L.**

Pol. Ind. Santa Ana C/ El Torno N°8  
CP 28522 Rivas Vaciamadrid, Madrid, ESPAÑA  
Tel. (+34) 913 001 435 Fax. (+34) 913 001 645  
dinacell@dinacell.com  
**www.dinacell.com**