

INSTRUCTION MANUAL OF LOAD CONTROL DEVICE LCK

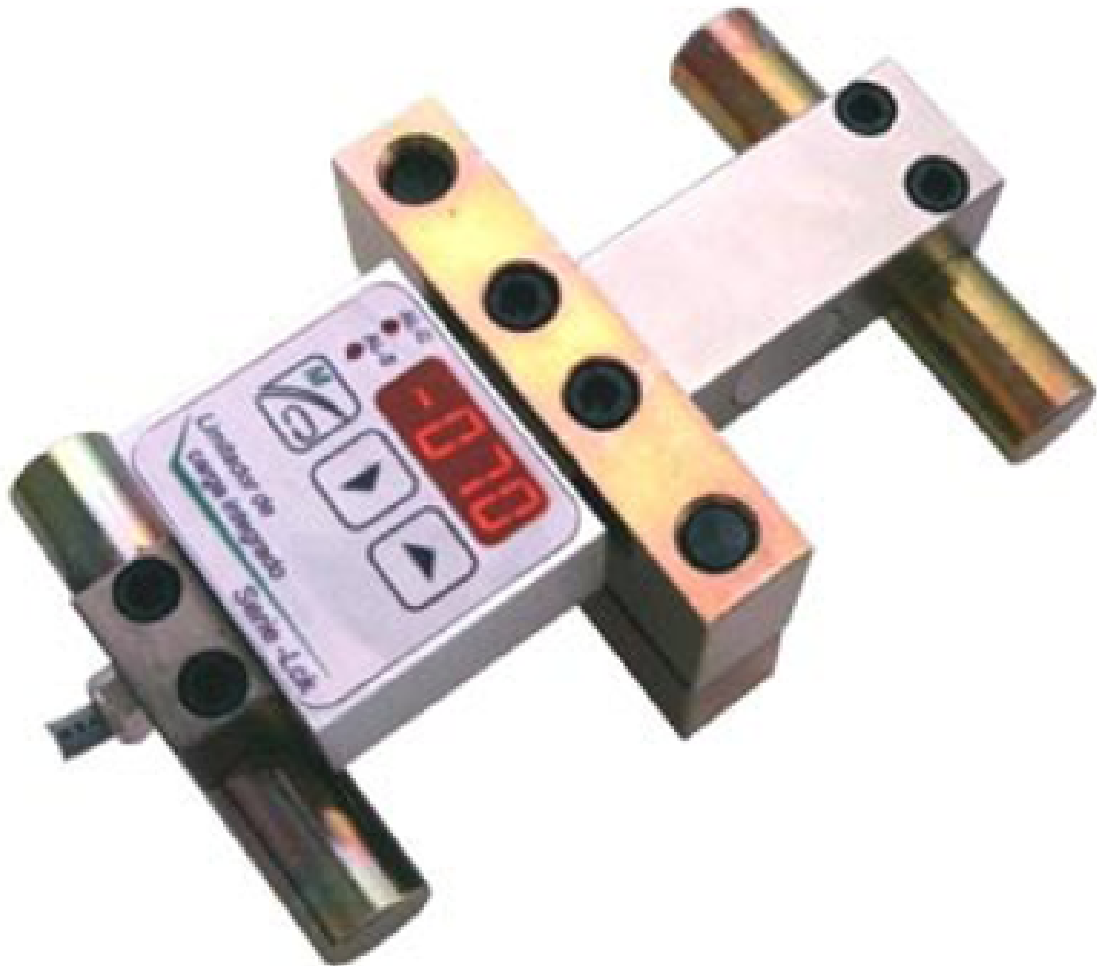

**Load control device
with integrated
electronics**

1. Dimensions

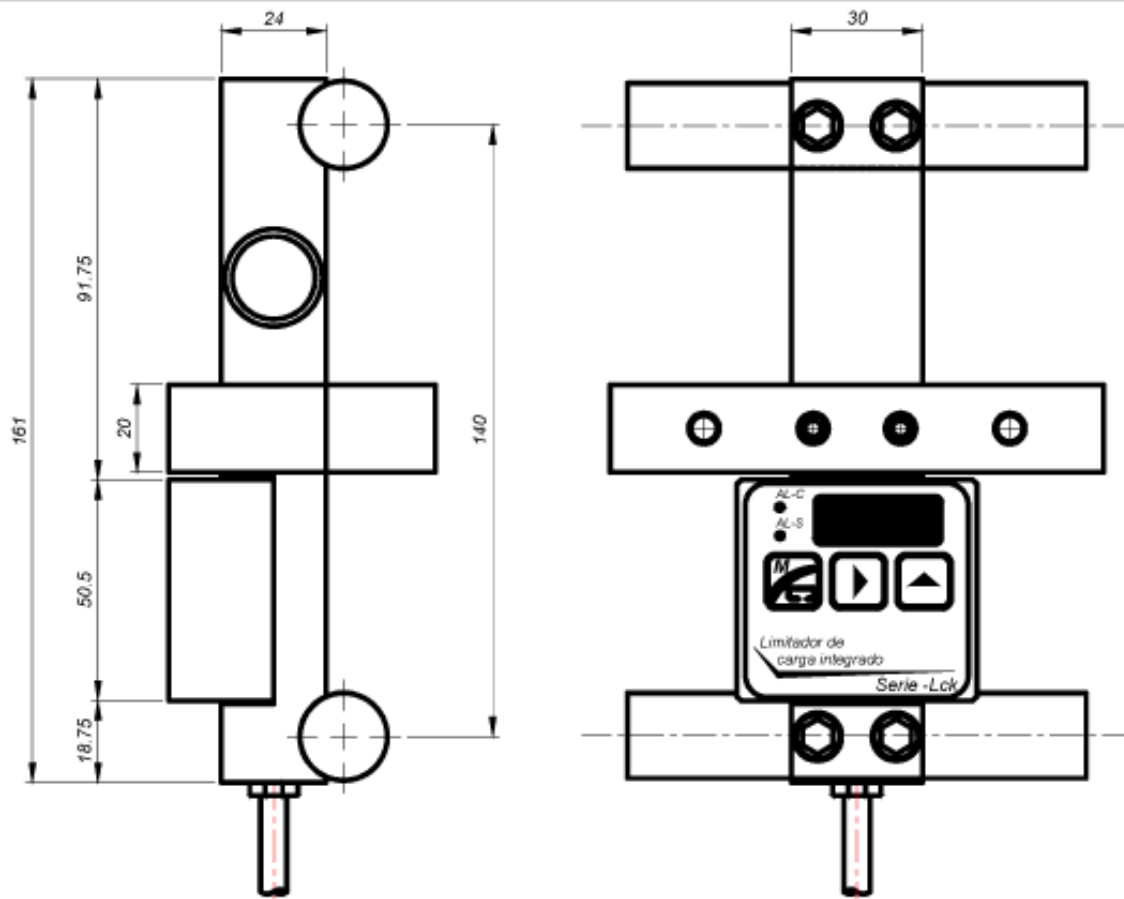

2. Description of the connections

Red	Positive power supply (24 - 48Vdc)
Black	Negative power supply
Violet	Relay contact of the complete load (AL-C)
Blue	
Pink	Relay contact of the overload (AL-S)
Brown	
Gray	Hold
White	
Yellow	Earth
Green	Not connected

AL-C (Relay contact of the Complete load)

Change of the state if the load programmed in the parameter `RL C` is overcome.

AL-S (Relay contact of the Overload)

Change of the state if the load programmed in the parameter `RL S` is overcome.



Note: The state of rest of the relay can change in the parameter of `CONF`

HOLD (It is activated with a tension between 24 & 220 V alternating or continuous). When the elevator is in progress, the measure of the weight is not good. The relay could be activated & the cabin display turns unstable.





Activating the entrance of **HOLD** when the elevator get in motion. The measure of weight is blocked, *then the display presenting in intermittent*, & the relay together with the cabin display conserves its state until this entrance is disabled, that should be after stopping the elevator.

3. Keys of access to the parameters of menu's

The unit has a menu to accede to the adjustment of the parameters.

-  Pressing this key successively, will go going to all programmable parameters of the menu in a cycle way.
To return to the visual presentation of weight, press the key several time till to arrive at the end of the menu, or just press it during *2 seconds*.
-  Pressing this key enters in the selected option and once inside we will be able to select the digit to modify.
-  Pressing this key will modify the selected digit.
Also,pressing this key when you are located on the selected parameter the display presents its content.

4. Modification of the parameter

- 1)Go pressing the key  successively until being located on the wanted parameter.
- 2) Press the key  to enter in modification of the parameter, being the left digit in intermitten.
- 3) Put in the display the wanted value, using this keys  
- 4) Press  2 times to save the assignated value. Then the display will present the next parameter.

Notes:

- a) If you haven't press the  for the 2nd time, the operation will not stored,and the display presents again the parameters that you was modifying.
- b) To modify the parameters PESQy CERO , please consult section **Nº.6**
(Calibration of the unit)

5. Programming Structure of the Menu's

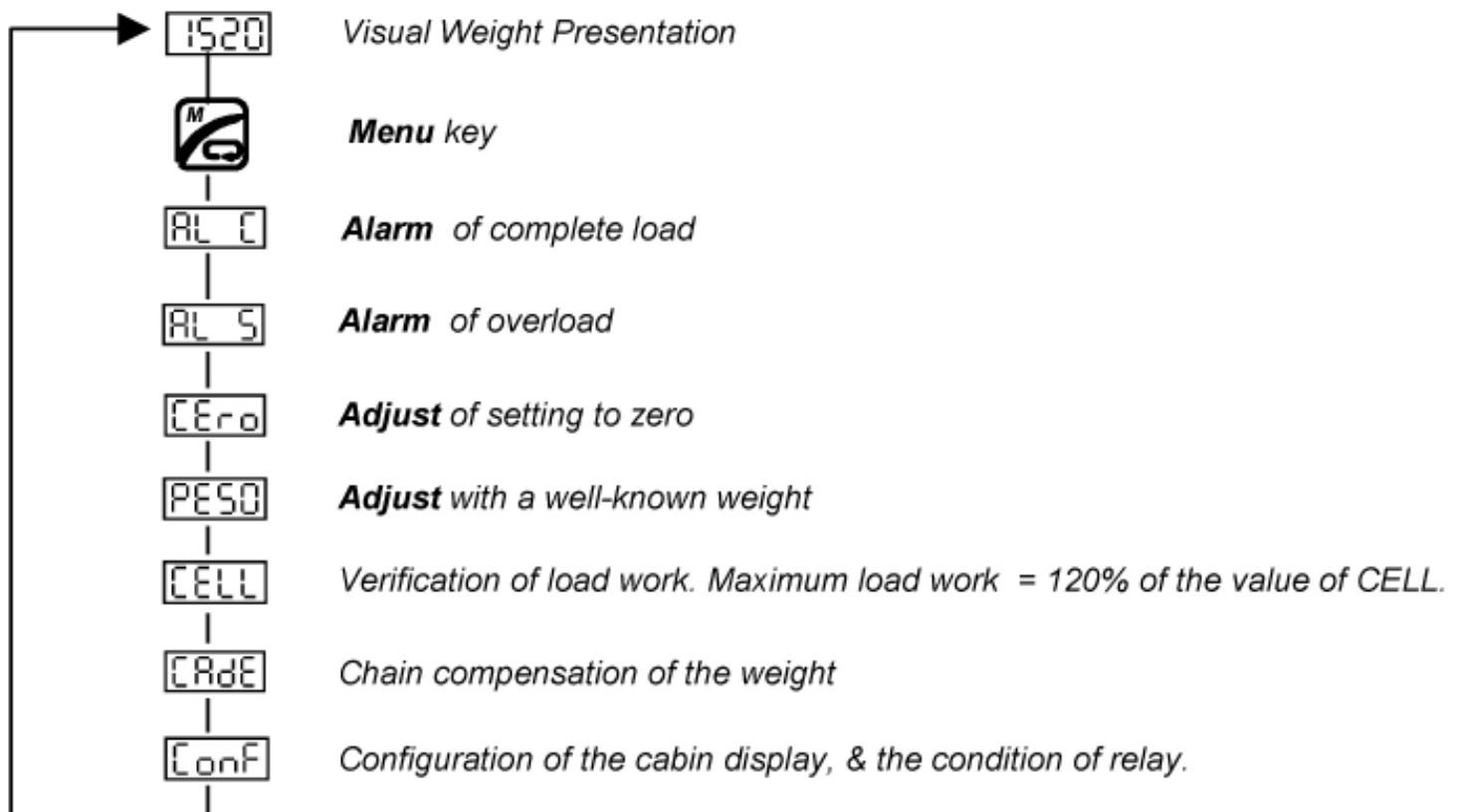

6. Calibration of the Unit.

This section is necessary so that the unit knows the relationship between the signal of the cell and the weight introduced in the cabin.

There are two ways to calibrate the unit:

1) Normal Calibration.

1) Setting of the Zero:

a) Situate in the option of menu **CEr0**

b) Check that the cabin is empty and press the key . The display menu **CEr0** will become intermittent during 10 seconds.

c) Press again the key  while is in intermittent so that the operation will be confirmed starting to count backward. And when it finished, the display will present the parameter **PE50**



Note: If you don't press the  before finishing the intermittence, the operation will not stored, and the display presents again the parameter **CEr0**.

2) Adjust of the Weight: (It is important to do the **setting of the zero** before doing this operation)

a) Situate in the option of menu **PE50**

b) Introduce **inside the cabin a well-known** weight & press 



Note: It is recommended at least as minimum **50%** of the complete load.

c) Put the value of the weight placed in the cabin using the keys  

d) To save the value press the key  , **2 times** (The unit will start to **count-down** and the value will be saved). Then the display will present the next parameter CELL

Note: If you haven't press the  for the 2nd time, the operation will not be stored, and the display presents again the parameter PES0 .

3) Auto-calibration System.

- 1) First do the setting of the CEr0 as what indicated on the normal calibration.
- 2) Introduced in the parameter CELL the **value** by using these keys  
you will find the **CELL value** on the label of the sensor (Ex.: CELL=3200)
- 3) Then the unit LCK will be automatically calibrated.

7. Alarms

The alarms are the load levels in which that change the state of the relay. To adjust them it is **not necessary any weight**, just program them on the keyboard.

AL C Value of the load indicating that the elevators is complete. When the content of the elevator overcome this value, the state of the relay change to indicate the **complete load**.

AL S Value of the load indicating that the elevator is in overload. When the content of the elevator overcome this value, the state of the relay change to **overload**.

Note: For the setting of the alarms, see section **Nº.4** (Modification of a parameter) .

8. Auxiliary Functions

[Ade] Option of the chain compensation. This option allows to compensate the difference of weight between floor taken place by the chain. To use this option it is necessary to introduce the approximate weight of the chain, keeping in mind that the allowed maximum value is 50kg. In the event of putting it to zero the chain compensation will be annulled.

[ConF] Allows to configure the output of cabin display and the condition of the relay:

Configuration	State of the relay
ConF = 0	ON
ConF = 1	ON
ConF = 2	OFF
ConF = 3	OFF

9. Mode of low consumption

As the display is the most that consumes and it is not an element that is visible. It has been keep in mind a way of a low consumption, that once the display turns off automatically, the display presents a rotating segment to indicate that it is continuously working.

Cases that the unit enters in the function of low consumption.

- 1) When connecting the unit to the power supply, it presents the weight during 3 minutes. And in the event of not playing any key, automatically it will pass to the mode of low consumption.
- 2) When it passed one hour since the last time that having played the key.
- 3) When the unit is presenting the weight, pressing the key  during two seconds.

Note: To leave the function of low consumption it is necessary to press any key

10. Electrical Characteristics

Model:..... **LCK**
Nominal tension:..... **24 - 48Vdc**
Nominal current:..... **<100mA.**

12. Presentation of Errors.

Err1 Load cell is damaged.

Err2 Negative Overflow .
-The load cell is working in a contrary sense or it is not well connected.

Err3 Positive Overflow. (The load cell is supporting a superior weight than the nominal value.)
-It is necessary to put a load cell that has a superior nominal value.

Err4 Polarity error. (This error can give if it is adjusted without placing a weight in the cabin)
-Repeat the setting of the zero(**Cero**) and the weight (**Peso**)

Err5 Lost of data in the memory.
-It is necessary to repeat the program of all the parameters.

Note: When an error takes place all the alarms will be activated and the elevator is blocked.

13. INSTALLATION GUIDE (Step by step)

This section explains the steps to follow for the installation of the load control device **LCK**.



1. INSTALL THE DEVICE WELL IN THE CABLES.
2. CONNECTS THE CABLES OF THE DEVICE RESPECTING THE COLORS CODE.
 - Look at section N° 2. (*Description of the connections*)
3. FEED THE INTEGRATED UNIT CONTROL.

*Quick guide to configure the most important parameters of the unit

- a) To find the parameter that is wanted to change press successively  and to accede to the parameter press 
- b) Modify using this keys  
- c) To save the data press 2 times 

4. MOST IMPORTANT PARAMETERS TO CONFIGURE:



A) Program the alarms:

- 1°. Put in  the value of the load, starting from which is required to activate the alarm of **complete load**.
- 2°. Put in  the value of the load, starting from which is required to activate the alarm of **overload**.

B) Set the Zero:

-Conditions before setting the zero:





1. Put down the cabin to an intermediate floor.
2. Bounce inside the cabin to avoid possible frictions.
3. The elevators should be empty.

Then set the **Zero** situating in the parameter  press   and will start to count-down.

C) Auto-calibration system:

- Just introduced the *value* of the **CELL** that you will find on the label.
(See section N°.6 . 3 **Auto-Calibration System**)).

D) Adjust of the Weight (PESO): “Optional operation”

- Put a well known weight inside the cabin (at least **50% of the complete load**)
- Introduce in the parameter  the value of the load that has been placed in the cabin using this keys  , then to save it press  2 times and the unit will start to count-down.

Note: It is important to configure the **setting of zero** before doing the operation of the **Auto-calibration system** or **either the Adjust of the Weight** .

5. NOW THE DEVICE IS READY FOR THE OPERATION..